

On the correspondence of interaction terms between light-cone superstring field theory and matrix string theory

Isao Kishimoto



Collaboration with S. Moriyama and S. Teraguchi

KMT, NPB744(2006)221 [hep-th/0603068]. KM, hep-th/0611113

Introduction and summary

It is important to make detailed investigations of nonperturbative formulations for string theory. Several formulations such as string field theories or matrix theories have been proposed.

It is preferable to understand relations among them to develop them correctly.

Dijkgraaf and Motl (2003) suggested that there is a correspondence between

Green-Schwarz-Brink's light-cone superstring field theory (1983)
and

Dijkgraaf-Verlinde-Verlinde's matrix string theory (1997) .

We concentrate on their interaction term:

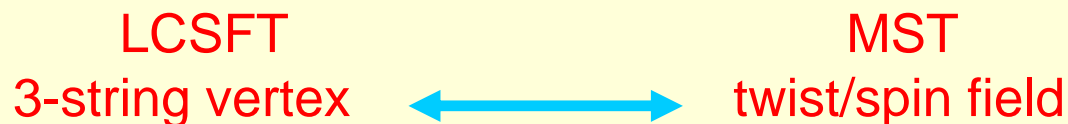

LCSFT

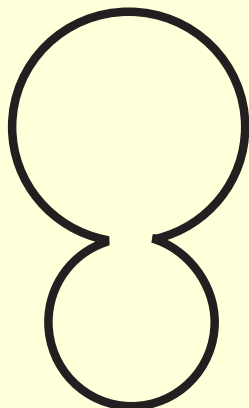
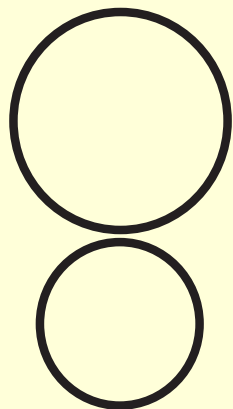

MST

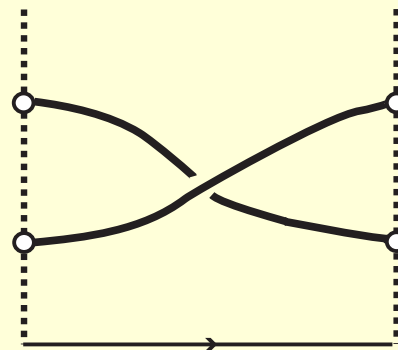
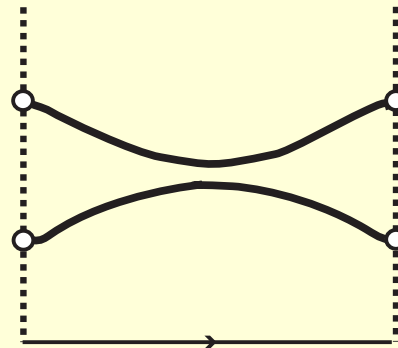

Comparing

$$\partial X^i(\sigma)|V\rangle \sim |\sigma - \sigma_{\text{int}}|^{-\frac{1}{2}} Z^i|V\rangle$$

$$\bar{\partial} X^i(\sigma)|V\rangle \sim |\sigma - \sigma_{\text{int}}|^{-\frac{1}{2}} \tilde{Z}^i|V\rangle$$

$$(|\sigma - \sigma_{\text{int}}| \rightarrow 0)$$

and

$$\partial X^i(z)\sigma\tilde{\sigma}(0) \sim z^{-\frac{1}{2}}\tau^i\tilde{\sigma}(0)$$

$$\bar{\partial} X^i(\bar{z})\sigma\tilde{\sigma}(0) \sim \bar{z}^{-\frac{1}{2}}\sigma\tilde{\tau}^i(0)$$

$$(z, \bar{z} \rightarrow 0)$$

we guess the correspondence:

$$\begin{array}{ccc} |V\rangle & \leftrightarrow & \sigma\tilde{\sigma} \\ Z^i|V\rangle & \leftrightarrow & \tau^i\tilde{\sigma} \\ \tilde{Z}^i|V\rangle & \leftrightarrow & \sigma\tilde{\tau}^i \end{array}$$

If the above correspondence is true, we expect that the OPE of the twist field in MST is reproduced by the 3-string vertex in LCSFT.

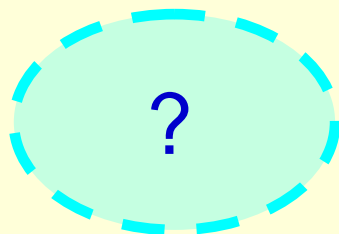

$$\sigma\tilde{\sigma}(z, \bar{z}) \cdot \sigma\tilde{\sigma}(0) \sim \left[\frac{1}{|z|(\ln|z|)^2} \right]^{\frac{d-2}{4}}$$

We have explicitly evaluated it in bosonic LCSFT as: [KMT]

$$\langle R(3,6) | e^{-\frac{T}{|\alpha_3|} (L_0^{(3)} + \tilde{L}_0^{(3)})} | V(1_{\alpha_1}, 2_{\alpha_2}, 3_{\alpha_3}) \rangle | V(4_{-\alpha_1}, 5_{-\alpha_2}, 6_{-\alpha_3}) \rangle$$

$$\sim \left[\frac{T}{|\alpha_{123}|^{1/3}} \left(\log \frac{T}{|\alpha_{123}|^{1/3}} \right)^2 \right]^{-6} |R(1,4)\rangle |R(2,5)\rangle$$

(tree)

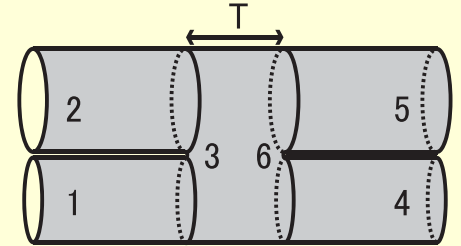

$$\langle R(2,5) | \langle R(1,4) | e^{-\frac{T}{\alpha_1} (L_0^{(1)} + \tilde{L}_0^{(1)}) - \frac{T}{\alpha_2} (L_0^{(2)} + \tilde{L}_0^{(2)})} | V(1_{\alpha_1}, 2_{\alpha_2}, 3_{\alpha_3}) \rangle | V(4_{-\alpha_1}, 5_{-\alpha_2}, 6_{-\alpha_3}) \rangle$$

$$\sim \left[\frac{T}{|\alpha_{123}|^{1/3}} \left(\log \frac{T}{|\alpha_{123}|^{1/3}} \right)^2 \right]^{-6} |R(3,6)\rangle$$

(1-loop)

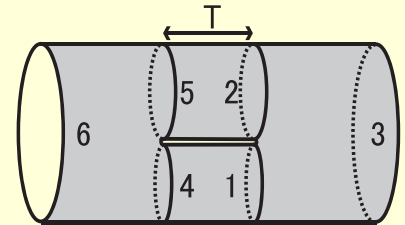

The result is consistent with the correspondence if we identify

$$|R\rangle \leftrightarrow 1$$

and $T \sim |\sigma - \sigma_{\text{int}}| \sim |z|$.

Similarly, we have evaluated the fermionic sector as: [KM]

$$\langle R | e^{-\frac{T}{|\alpha_3|}(L_0^{(3)} + \tilde{L}_0^{(3)})} v^{ij}(Y) | V \rangle v^{kl}(Y) | V \rangle \sim \delta^{ik} \delta^{jl} T^{-2} | R \rangle | R \rangle$$

$$\langle R | \langle R | e^{-\frac{T}{\alpha_1}(L_0^{(1)} + \tilde{L}_0^{(1)})} e^{-\frac{T}{\alpha_2}(L_0^{(2)} + \tilde{L}_0^{(2)})} v^{ij}(Y) | V \rangle v^{kl}(Y) | V \rangle \sim \delta^{ik} \delta^{jl} T^{-2} | R \rangle$$

$$\langle R | e^{-\frac{T}{|\alpha_3|}(L_0^{(3)} + \tilde{L}_0^{(3)})} s^{i\dot{a}}(Y) | V \rangle s^{j\dot{b}}(Y) | V \rangle \sim \delta^{ij} \delta^{\dot{a}\dot{b}} T^{-2} | R \rangle | R \rangle$$

$$\langle R | \langle R | e^{-\frac{T}{\alpha_1}(L_0^{(1)} + \tilde{L}_0^{(1)})} e^{-\frac{T}{\alpha_2}(L_0^{(2)} + \tilde{L}_0^{(2)})} s^{i\dot{a}}(Y) | V \rangle s^{j\dot{b}}(Y) | V \rangle \sim \delta^{ij} \delta^{\dot{a}\dot{b}} T^{-2} | R \rangle$$

⋮

On the other hand, the OPEs among spin fields are

$$\Sigma^i(z) \Sigma^j(0) \sim z^{-1} \delta^{ij},$$

$$\Sigma^{\dot{a}}(z) \Sigma^{\dot{b}}(0) \sim z^{-1} \delta^{\dot{a}\dot{b}},$$

$$\Sigma^i(z) \Sigma^{\dot{a}}(0) \sim z^{-\frac{1}{2}} \frac{1}{\sqrt{2i}} \gamma_{c\dot{a}}^i \theta^c(0), \dots$$

Our results on the contractions are consistent with the correspondence:

$$\begin{aligned}
 H_1 & : & v^{ij}(Y)|V\rangle & \leftrightarrow & \Sigma^j \tilde{\Sigma}^i \\
 Q_1^{\dot{a}} & : & s^{i\dot{a}}(Y)|V\rangle & \leftrightarrow & \Sigma^{\dot{a}} \tilde{\Sigma}^i \\
 \tilde{Q}_1^{\dot{a}} & : & \tilde{s}^{i\dot{a}}(Y)|V\rangle & \leftrightarrow & \Sigma^i \tilde{\Sigma}^{\dot{a}}
 \end{aligned}$$

which are given by [\[Dijkgraaf-Motl\]](#).

In our computations in LCSFT, we found a simple expression of the prefactor

$$e^{\mathcal{Y}} = [e^{\mathcal{Y}}]_{(i,\dot{a}), (j,\dot{b})} = \begin{pmatrix} [\cosh \mathcal{Y}]_{ij} & [\sinh \mathcal{Y}]_{i\dot{b}} \\ [\sinh \mathcal{Y}]_{\dot{a}j} & [\cosh \mathcal{Y}]_{\dot{a}\dot{b}} \end{pmatrix} = \begin{pmatrix} v^{ij}(Y) & i(-\alpha_{123})^{-\frac{1}{2}} s^{i\dot{b}}(Y) \\ (-\alpha_{123})^{-\frac{1}{2}} \tilde{s}^{j\dot{a}}(Y) & m^{\dot{b}\dot{a}}(Y) \end{pmatrix},$$

$$\mathcal{Y} \equiv \left(\frac{2i}{-\alpha_{123}} \right)^{\frac{1}{2}} Y^a \hat{\gamma}^a, \quad \hat{\gamma}^a = (\hat{\gamma}^a)_{(i,\dot{a}), (j,\dot{b})} = \begin{pmatrix} 0 & \gamma_{ab}^i \\ \gamma_{a\dot{a}}^j & 0 \end{pmatrix}, \quad \hat{\gamma}^a \hat{\gamma}^b + \hat{\gamma}^b \hat{\gamma}^a = 2\delta^{ab} \mathbf{1}_{16}.$$

Comment

In [I.K.-Matsuo-Watanabe2, I.K.-Matsuo2], we evaluated the coefficients of the idempotency relation for the boundary states as

$$|B\rangle_{\alpha_1} *_T |B\rangle_{\alpha_2} \sim |\alpha_{123}| T^{-3} |B\rangle_{\alpha_1 + \alpha_2}$$

in the HIKKO closed SFT (d=26) .

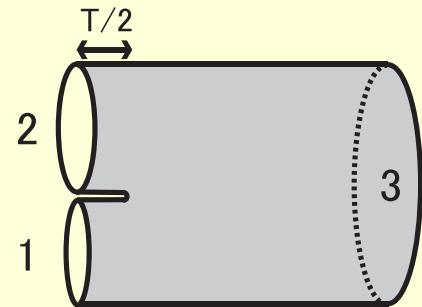

Therefore, in the case of

$$\langle R(2,5) | \langle R(1,4) | e^{-\frac{T}{\alpha_1}(L_0^{(1)} + \tilde{L}_0^{(1)}) - \frac{T}{\alpha_2}(L_0^{(2)} + \tilde{L}_0^{(2)})} | V(1_{\alpha_1}, 2_{\alpha_2}, 3_{\alpha_3}) \rangle | V(4_{-\alpha_1}, 5_{-\alpha_2}, 6_{-\alpha_3}) \rangle$$

we expected that the coefficient behaves as $\sim (T^{-3})^2 = T^{-6}$ for bosonic LCSFT.

This estimation is consistent with the conformal dimension of the twist field:

$$\left(\frac{1}{16} + \frac{1}{16} \right) (\text{conf. dim. of } \sigma\tilde{\sigma}) \times 2 (\sigma\tilde{\sigma} \cdot \sigma\tilde{\sigma}) \times (26 - 2) (\text{transverse}) = 6.$$

Contents

- Introduction and summary
- LCSFT/MST Correspondence
 - Brief review of LCSFT [Green-Schwarz-Brink]
 - Brief review of MST [Dijkgraaf-Verlinde-Verlinde]
 - Review of previous results on the correspondence [Dijkgraaf-Motl], [Moriyama]
- Contractions in bosonic LCSFT [KMT]
- A simple form of the prefactors [KM]
- Contractions in super LCSFT [KM]
- Conclusion and future directions

LCSFT/MST Correspondence

- Brief review of light-cone superstring field theory (GSB: $SO(8)$ formalism)

Green-Schwarz formalism \rightarrow light-cone gauge

String field Φ : functional of x^+, x^- and

$$X^i(\sigma) = x^i + i \sum_{n \neq 0} \frac{1}{n} (\alpha_n^i e^{in\frac{\sigma}{|\alpha|}} + \tilde{\alpha}_n^i e^{-in\frac{\sigma}{|\alpha|}}), \quad [\alpha_n^i, \alpha_m^j] = n\delta_{n+m,0}\delta^{ij}, \dots$$

$$\vartheta^a(\sigma) = \vartheta^a + \sum_{n \neq 0} \frac{1}{\alpha} (\eta^* Q_n^a e^{in\frac{\sigma}{|\alpha|}} + \eta \tilde{Q}_n^a e^{-in\frac{\sigma}{|\alpha|}}), \quad \{Q_n^a, Q_m^b\} = \alpha\delta_{n+m,0}\delta^{ab}, \dots$$

$$(\eta = e^{\frac{i\pi}{4}}, \eta^* = e^{-\frac{i\pi}{4}})$$

bra-ket representation

$$|\Phi\rangle = \sum_{x^+, \alpha, p, \lambda} f_{x^+, \alpha, p, \lambda}^{i_1 n_1 \dots j_1 m_1 \dots a_1 l_1 \dots b_1 k_1 \dots} \alpha_{-n_1}^{i_1} \dots \tilde{\alpha}_{-m_1}^{j_1} \dots Q_{-l_1}^{a_1} \dots \tilde{Q}_{-k_1}^{b_1} \dots |\alpha, p^i, \lambda^a\rangle$$

(α, p^i, λ^a) : conjugate momentum of (x^-, x^i, ϑ^a)

Free Hamiltonian and super charge

$$\begin{aligned}
 H_0 &= \alpha^{-1}(L_0 + \tilde{L}_0 - 1), \\
 L_0 &= \frac{1}{2}p^i p^i + \sum_{n \geq 1} \alpha_{-n}^i \alpha_n^i + \sum_{n \geq 1} (n/\alpha) Q_{-n}^a Q_n^a + \frac{1}{2}, \\
 \tilde{L}_0 &= \frac{1}{2}p^i p^i + \sum_{n \geq 1} \tilde{\alpha}_{-n}^i \tilde{\alpha}_n^i + \sum_{n \geq 1} (n/\alpha) \tilde{Q}_{-n}^a \tilde{Q}_n^a + \frac{1}{2}, \\
 Q_0^{\dot{a}} &= \sqrt{2}\alpha^{-1} \sum_{n \in \mathbb{Z}} \gamma_{a\dot{a}}^i Q_{-n}^a \alpha_n^i, \\
 \tilde{Q}_0^{\dot{a}} &= \sqrt{2}\alpha^{-1} \sum_{n \in \mathbb{Z}} \gamma_{a\dot{a}}^i \tilde{Q}_{-n}^a \tilde{\alpha}_n^i.
 \end{aligned}$$

They satisfy the SUSY algebra:

$$\begin{aligned}
 \{Q_0^{\dot{a}}, Q_0^{\dot{b}}\} &= 2H_0 \delta^{\dot{a}\dot{b}} + 2\alpha^{-1}(L_0 - \tilde{L}_0) \delta^{\dot{a}\dot{b}}, \\
 \{\tilde{Q}_0^{\dot{a}}, \tilde{Q}_0^{\dot{b}}\} &= 2H_0 \delta^{\dot{a}\dot{b}} - 2\alpha^{-1}(L_0 - \tilde{L}_0) \delta^{\dot{a}\dot{b}}, \\
 [Q_0^{\dot{a}}, H_0] &= 0, \quad [\tilde{Q}_0^{\dot{a}}, H_0] = 0, \quad \{Q_0^{\dot{a}}, \tilde{Q}_0^{\dot{b}}\} = 0,
 \end{aligned}$$

up to the level matching condition $L_0 - \tilde{L}_0 = 0$.

Connection condition for 3 closed strings

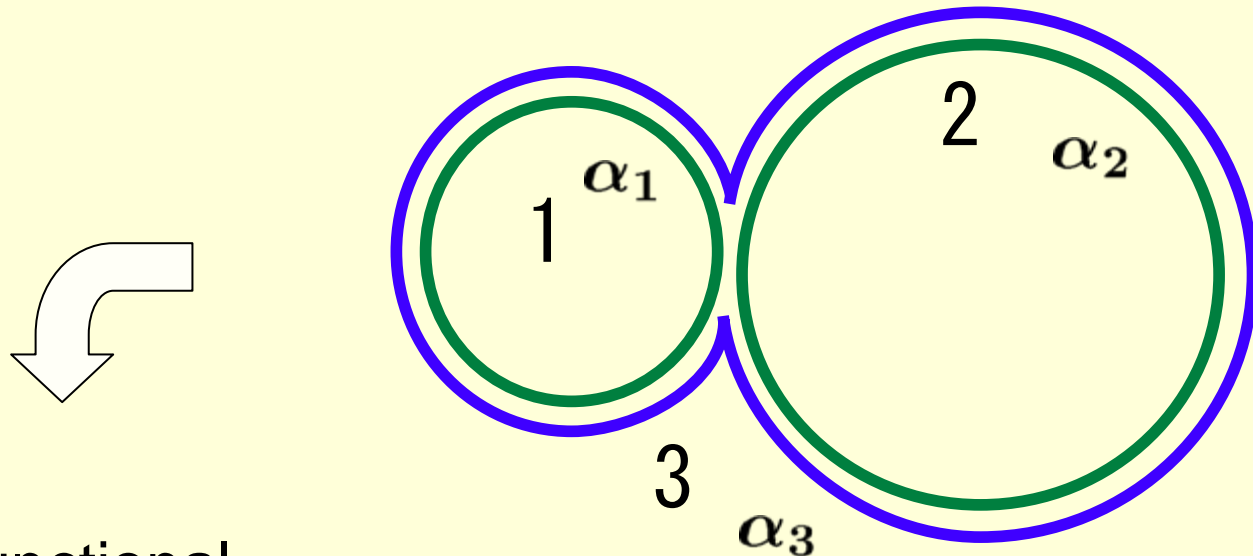

Delta functional

$$\delta(\alpha_1 + \alpha_2 + \alpha_3) \delta^8(X^{i(3)} - \Theta_1 X^{i(1)} - \Theta_2 X^{i(2)}) \delta^8(\vartheta^{(3)} - \Theta_1 \vartheta^{(1)} - \Theta_2 \vartheta^{(2)}) \\ = \langle \alpha_1, X^{i(1)}, \vartheta^{a(1)} | \langle \alpha_2, X^{i(2)}, \vartheta^{a(2)} | \langle \alpha_3, X^{i(3)}, \vartheta^{a(3)} | V(1, 2, 3) \rangle .$$



3-string vertex

Oscillator representation

$$\begin{aligned}
 |V(1, 2, 3)\rangle &= (2\pi)^9 \delta(\alpha_1 + \alpha_2 + \alpha_3) \delta^8(p_1^i + p_2^i + p_3^i) \delta^8(\lambda_1^a + \lambda_2^a + \lambda_3^a) \\
 &\times e^{\frac{1}{2} \sum \bar{N}_{nm}^{rs} (\alpha_{-n}^{(r)} \alpha_{-n}^{(s)} + \tilde{\alpha}_{-n}^{(r)} \tilde{\alpha}_{-n}^{(s)}) + \sum \bar{N}_n^r (\alpha_{-n}^{(r)} + \tilde{\alpha}_{-n}^{(r)}) P - \frac{\tau_0}{\alpha_{123}} P^2} \\
 &\times e^{\sum Q_{-n}^{II(r)} \alpha_r^{-1} n \bar{N}_{nm}^{rs} Q_{-m}^{I(s)} - \sqrt{2} \Lambda \sum \alpha_r^{-1} n \bar{N}_n^r Q_{-n}^{II(r)}} |0\rangle.
 \end{aligned}$$

where

$$P^i = \alpha_1 p_2^i - \alpha_2 p_1^i, \quad \Lambda^a = \alpha_1 \lambda_2^a - \alpha_2 \lambda_1^a, \quad Q_{-n}^{I/IIa} = \frac{1}{\sqrt{2}} (\eta^{\pm 1} Q_{-n}^a + \eta^{*\pm 1} \tilde{Q}_{-n}^a)$$

and the Neumann coefficients are explicitly given by

$$\bar{N}_{mn}^{rs} = -\alpha_{123} \left(\frac{\alpha_r}{m} + \frac{\alpha_s}{n} \right)^{-1} \bar{N}_m^r \bar{N}_n^s,$$

$$\bar{N}_m^r = \frac{1}{\alpha_r} \frac{\Gamma(-m\alpha_{r+1}/\alpha_r)}{m! \Gamma(1 - m(1 + \alpha_{r+1}/\alpha_r))} e^{m\tau_0/\alpha_r},$$

$$\alpha_{123} = \alpha_1 \alpha_2 \alpha_3, \quad (\alpha_4 \equiv \alpha_1), \quad \tau_0 = \sum_{r=1}^3 \alpha_r \log |\alpha_r|.$$

Interaction terms of Hamiltonian and super charges are constructed from SUSY algebra:

$$\begin{aligned}
 H &= H_0 + g_s H_1 + g_s^2 H_2 + \cdots, \\
 Q^{\dot{a}} &= Q_0^{\dot{a}} + g_s Q_1^{\dot{a}} + g_s^2 Q_2^{\dot{a}} + \cdots, \quad \tilde{Q}^{\dot{a}} = \tilde{Q}_0^{\dot{a}} + g_s \tilde{Q}_1^{\dot{a}} + g_s^2 \tilde{Q}_2^{\dot{a}} + \cdots, \\
 \{Q^{\dot{a}}, Q^{\dot{b}}\} &= \{\tilde{Q}^{\dot{a}}, \tilde{Q}^{\dot{b}}\} = 2H\delta^{\dot{a}\dot{b}}, \quad [Q^{\dot{a}}, H] = [\tilde{Q}^{\dot{a}}, H] = \{Q^{\dot{a}}, \tilde{Q}^{\dot{b}}\} = 0.
 \end{aligned}$$

The first nontrivial terms $H_1, Q_1^{\dot{a}}, \tilde{Q}_1^{\dot{a}}$ should satisfy

$$\begin{aligned}
 \sum_{r=1}^3 Q_0^{\dot{a}(r)} |Q_1^{\dot{b}}\rangle + \sum_{r=1}^3 Q_0^{\dot{b}(r)} |Q_1^{\dot{a}}\rangle &= \sum_{r=1}^3 \tilde{Q}_0^{\dot{a}(r)} |\tilde{Q}_1^{\dot{b}}\rangle + \sum_{r=1}^3 \tilde{Q}_0^{\dot{b}(r)} |\tilde{Q}_1^{\dot{a}}\rangle = 2|H_1\rangle\delta^{\dot{a}\dot{b}}, \\
 \sum_{r=1}^3 Q_0^{\dot{a}(r)} |\tilde{Q}_1^{\dot{b}}\rangle + \sum_{r=1}^3 \tilde{Q}_0^{\dot{b}(r)} |Q_1^{\dot{a}}\rangle &= 0
 \end{aligned}$$

up to the level matching condition $L_0^{(r)} - \tilde{L}_0^{(r)} = 0$, ($r = 1, 2, 3$).

They are given by the following form:

$$\begin{aligned}
 |H_1(1, 2, 3)\rangle &= \tilde{Z}^i Z^j v^{ij}(Y) |V(1, 2, 3)\rangle, \\
 |Q_1^{\dot{a}}(1, 2, 3)\rangle &= \tilde{Z}^i s^{i\dot{a}}(Y) |V(1, 2, 3)\rangle, \\
 |\tilde{Q}_1^{\dot{a}}(1, 2, 3)\rangle &= Z^i \tilde{s}^{i\dot{a}}(Y) |V(1, 2, 3)\rangle.
 \end{aligned}$$

$$\tilde{Z}^i = P^i - \alpha_{123} \sum \alpha_r^{-1} n \bar{N}_n^r \tilde{\alpha}_{-n}^{(r)i},$$

Here $Z^j = P^j - \alpha_{123} \sum \alpha_r^{-1} n \bar{N}_n^r \alpha_{-n}^{(r)j}$, commute with the connection condition

$$Y^a = \Lambda^a - \frac{\alpha_{123}}{\sqrt{2}} \alpha_r^{-1} n \bar{N}_n^r Q_{-n}^{I(r)a}$$

and the prefactors are given by some particular polynomials:

$$\begin{aligned} v^{ij}(Y) = & \delta^{ij} - \frac{i}{\alpha_{123}} \gamma_{ab}^{ij} Y^a Y^b + \frac{1}{6(\alpha_{123})^2} t_{abcd}^{ij} Y^a Y^b Y^c Y^d \\ & - \frac{4i}{6!(\alpha_{123})^3} \gamma_{ab}^{ij} \epsilon^{abcdefgh} Y^c Y^d Y^e Y^f Y^g Y^h \\ & + \frac{16}{8!(\alpha_{123})^4} \delta^{ij} \epsilon^{abcdefgh} Y^a Y^b Y^c Y^d Y^e Y^f Y^g Y^h, \end{aligned}$$

$$s_1^{i\dot{a}}(Y) = 2\gamma_{a\dot{a}}^i Y^a + \frac{8}{6!\alpha_{123}^2} u_{abc}^{i\dot{a}} \epsilon^{abcdefgh} Y^d Y^e Y^f Y^g Y^h,$$

$$s_2^{i\dot{a}}(Y) = -\frac{2}{3\alpha_{123}} u_{abc}^{i\dot{a}} Y^a Y^b Y^c + \frac{16}{7!\alpha_{123}^3} \gamma_{a\dot{a}}^i \epsilon^{abcdefgh} Y^b Y^c Y^d Y^e Y^f Y^g Y^h,$$

$$s^{i\dot{a}}(Y) = \frac{\eta^*}{\sqrt{2}} (s_1^{i\dot{a}}(Y) - i s_2^{i\dot{a}}(Y)),$$

$$\tilde{s}^{i\dot{a}}(Y) = \frac{\eta}{\sqrt{2}} (s_1^{i\dot{a}}(Y) + i s_2^{i\dot{a}}(Y)),$$

$$\gamma^i = \begin{pmatrix} & \gamma_{a\dot{a}}^i \\ \tilde{\gamma}_{\dot{a}a}^i & \end{pmatrix}, \quad \tilde{\gamma}_{\dot{a}a}^i = \gamma_{a\dot{a}}^i, \quad u_{abc}^{i\dot{a}} = \gamma_{[ab}^{ji} \gamma_{c]\dot{a}}^j, \quad t_{abcd}^{ij} = \gamma_{[ab}^{ik} \gamma_{cd]}^{jk}.$$

- Brief review of matrix string theory

From BFSS's Matrix theory (dimensional reduction from 1+9 dim. $U(N)$ SYM to 1+0 dim.), compactifying on the circle in the target space, we have 2 dimensional action:

$$S = \int dt \int_0^{2\pi} d\sigma \operatorname{tr} \left(-\frac{1}{2} (D_\mu X^i)^2 + \theta^T \not{D} \theta - \frac{1}{4} g_s^2 F_{\mu\nu}^2 + \frac{1}{4g_s^2} [X^i, X^j]^2 + \frac{1}{g_s} \theta^T \gamma^i [X^i, \theta] \right)$$

At the free string limit: $\frac{1}{g_{\text{YM}}} = g_s \rightarrow 0$

main contribution comes from $[X^i, X^j] = 0$.

Diagonalizing the matrices, $(U^{-1}X^iU)_{mn} = x_m^i \delta_{m,n}$

periodicity up to $U(N)$ gauge transformation $X^i(\sigma + 2\pi) = VX^i(\sigma)V^{-1}$

implies $x^i(\sigma + 2\pi) = gx^i(\sigma)g^{-1}, \quad g \in S_N.$

matrix string theory

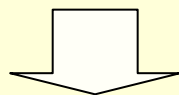

CFT

worldsheet field $x_m^i, \theta_m^a, \tilde{\theta}_m^{\dot{a}}, \quad (m = 1, \dots, N)$
 $\delta_v \quad \delta_s \quad \delta_c$

target space \mathbb{R}^{8N}/S_N

Twisted sector: long strings

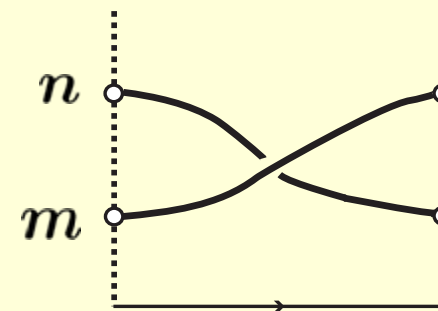
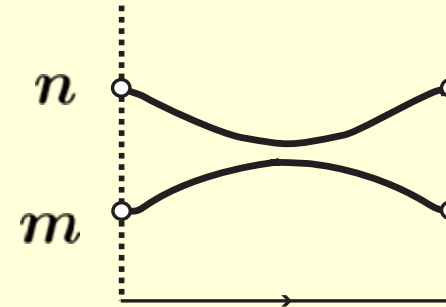
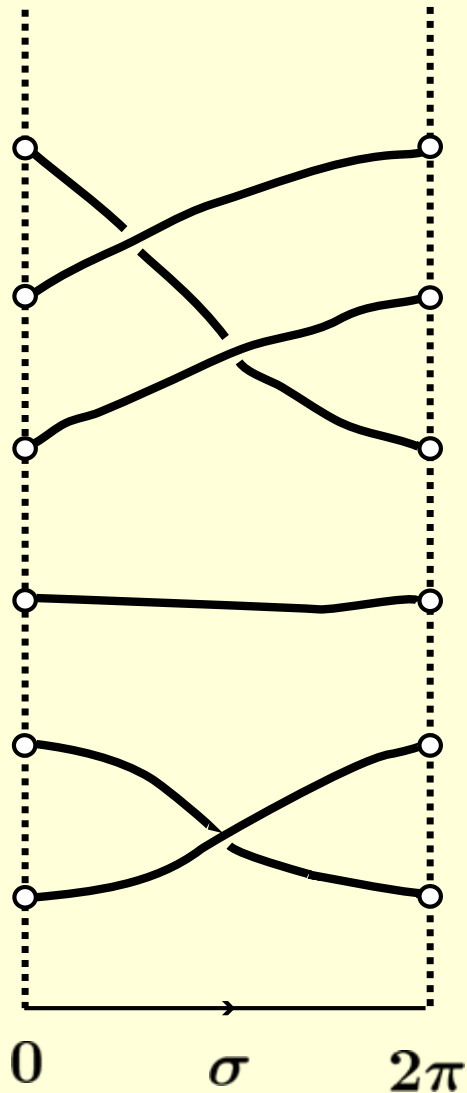

interaction
 ~ exchange of eigenvalues

Interaction: exchange of eigenvalues

\mathbf{Z}_2 twist field/ spin field

$$\begin{aligned}
 (\partial x_n^i(z) - \partial x_m^i(z))(\sigma \tilde{\sigma}(0))_{(nm)} &\sim z^{-\frac{1}{2}}(\tau^i \tilde{\sigma}(0))_{(nm)}, \\
 (\bar{\partial} x_n^i(\bar{z}) - \bar{\partial} x_m^i(\bar{z}))(\sigma \tilde{\sigma}(0))_{(nm)} &\sim \bar{z}^{-\frac{1}{2}}(\sigma \tilde{\tau}^i(0))_{(nm)}, \\
 (\theta_n^a(z) - \theta_m^a(z))(\Sigma^i(0))_{(nm)} &\sim z^{-\frac{1}{2}} \frac{1}{\sqrt{2}i} \gamma_{a\dot{a}}^i (\Sigma^{\dot{a}}(0))_{(nm)}, \\
 &\vdots
 \end{aligned}$$

Interaction term: $g_s \sqrt{\alpha'} \int d^2 z V_{\text{int}}$

Lorentz scalar, conformal dimension (3/2,3/2)

$$V_{\text{int}} = \sum_{n < m} (\tau^i \Sigma^i \tilde{\tau}^j \tilde{\Sigma}^j)_{(nm)}$$

conformal dimension: $\left(\frac{1}{16} \times 8 + \frac{1}{2}\right) + \frac{1}{2} = \frac{3}{2}$

- Review of previous results on the correspondence

Correspondence in the bosonic sector

We fix and drop (n, m) and rewrite as $x_n^i - x_m^i \rightarrow X^i$.

Comparing the OPE of the \mathbf{Z}_2 twist field: $\partial X^i(z)\sigma\tilde{\sigma}(0) \sim z^{-\frac{1}{2}}\tau^i\tilde{\sigma}(0)$,
 (MST) $\bar{\partial}X^i(\bar{z})\sigma\tilde{\sigma}(0) \sim \bar{z}^{-\frac{1}{2}}\sigma\tilde{\tau}^i(0)$,

with the result of direct computation $\frac{1}{2}(\partial X^{(1)i}(\sigma_1) + \partial X^{(1)i}(-\sigma_1))|V\rangle \sim \frac{1}{4\pi|\alpha_{123}|^{1/2}|\sigma_1 - \sigma_{\text{int}}^{(1)}|^{1/2}}Z^i|V\rangle$,
 (LCSFT) : $\frac{1}{2}(\bar{\partial}X^{(1)i}(\sigma_1) + \bar{\partial}X^{(1)i}(-\sigma_1))|V\rangle \sim \frac{1}{4\pi|\alpha_{123}|^{1/2}|\sigma_1 - \sigma_{\text{int}}^{(1)}|^{1/2}}\tilde{Z}^i|V\rangle$,

where $\partial X^{(1)i}(\sigma_1) \equiv \frac{1}{2\pi\alpha_1} \sum_{n=-\infty}^{\infty} \alpha_n^{(1)i} e^{-in\frac{\sigma_1}{\alpha_1}}$, $\bar{\partial}X^{(1)i}(\sigma_1) \equiv \frac{1}{2\pi\alpha_1} \sum_{n=-\infty}^{\infty} \tilde{\alpha}_n^{(1)i} e^{in\frac{\sigma_1}{\alpha_1}}$, $\sigma_{\text{int}}^{(1)} = \pm\pi\alpha_1$,

we expect the correspondence:

$$\begin{aligned} |V\rangle_b &\leftrightarrow \sigma\tilde{\sigma}, \\ |\tilde{Q}_1^{\dot{a}}\rangle &\Rightarrow Z^i|V\rangle_b \leftrightarrow \tau^i\tilde{\sigma}, \\ |Q_1^{\dot{a}}\rangle &\Rightarrow \tilde{Z}^i|V\rangle_b \leftrightarrow \sigma\tilde{\tau}^i, \\ |H_1\rangle &\Rightarrow \tilde{Z}^i Z^j|V\rangle_b \leftrightarrow \tau^j\tilde{\tau}^i. \end{aligned}$$

Correspondence in the Fermionic sector

[Dijkgraaf-Motl]

In the MST side, we consider type IIB version.

We fix and drop (n, m) and rewrite as $\theta_n^a - \theta_m^a \rightarrow \theta^a$, $\tilde{\theta}_n^a - \tilde{\theta}_m^a \rightarrow \tilde{\theta}^a$.

The OPE of spin fields is

$$\theta^a(z)\Sigma^i(0) \sim z^{-\frac{1}{2}} \frac{\eta^*}{\sqrt{2}} \gamma_{a\dot{a}}^i \Sigma^{\dot{a}}(0), \quad \theta^a(z)\Sigma^{\dot{a}}(0) \sim z^{-\frac{1}{2}} \frac{\eta}{\sqrt{2}} \gamma_{a\dot{a}}^i \Sigma^i(0),$$

$$\tilde{\theta}^a(z)\tilde{\Sigma}^i(0) \sim \bar{z}^{-\frac{1}{2}} \frac{\eta^*}{\sqrt{2}} \gamma_{a\dot{a}}^i \tilde{\Sigma}^{\dot{a}}(0), \quad \tilde{\theta}^a(z)\tilde{\Sigma}^{\dot{a}}(0) \sim \bar{z}^{-\frac{1}{2}} \frac{\eta}{\sqrt{2}} \gamma_{a\dot{a}}^i \tilde{\Sigma}^i(0),$$

and then

$$\frac{\eta^*}{\sqrt{2}} \left(\theta^a(z) + i\tilde{\theta}^a(\bar{z}) \right) (\Sigma^i \tilde{\Sigma}^i - \Sigma^{\dot{a}} \tilde{\Sigma}^{\dot{a}})(0) \sim |z|^{-\frac{1}{2}} (-i) \gamma_{a\dot{a}}^i (\Sigma^{\dot{a}} \tilde{\Sigma}^i - i \Sigma^i \tilde{\Sigma}^{\dot{a}})(0),$$

(MST) (for $z = \bar{z} > 0$).

From direct computation,

we have

$$\lambda^{(1)a}(\sigma_1)|V\rangle \sim \lambda^{(1)a}(-\sigma_1)|V\rangle \sim \frac{1}{4\pi|\alpha_{123}|^{1/2}|\sigma_1 - \sigma_{\text{int}}^{(1)}|^{1/2}} Y^a|V\rangle,$$

where

$$\lambda^{(1)a}(\sigma_1) \equiv \frac{1}{2\pi\alpha_1} \left[\lambda^a + \frac{1}{2} \sum_{n \neq 0} \left(\eta Q_n^{(1)} e^{in\frac{\sigma_1}{\alpha_1}} + \eta^* \tilde{Q}_n^{(1)} e^{-in\frac{\sigma_1}{\alpha_1}} \right) \right].$$

(LCSFT)

Suppose

$$|V\rangle_f \leftrightarrow (\Sigma^i \tilde{\Sigma}^i - \Sigma^{\dot{a}} \tilde{\Sigma}^{\dot{a}})(0),$$

$$Y^a \leftrightarrow \Lambda_+^a \equiv \frac{\eta^* \alpha_{123}^{1/2}}{2} \left(\sqrt{z} \theta^a(z) + i \sqrt{\bar{z}} \tilde{\theta}^a(\bar{z}) \right),$$

then we have following correspondence:

$$Y^a |V\rangle_f \leftrightarrow : \Lambda_+^a (\Sigma^i \tilde{\Sigma}^i - \Sigma^{\dot{a}} \tilde{\Sigma}^{\dot{a}}) := -i \left(\frac{\alpha_{123}}{2} \right)^{\frac{1}{2}} \gamma_{a\dot{a}}^i (\Sigma^{\dot{a}} \tilde{\Sigma}^i - i \Sigma^i \tilde{\Sigma}^{\dot{a}}),$$

$$Y^a Y^b |V\rangle_f \leftrightarrow -i \frac{\alpha_{123}}{2} \gamma_{ab}^{ij} \left(\Sigma^i \tilde{\Sigma}^j - \frac{1}{4} \tilde{\gamma}_{\dot{a}\dot{b}}^{ij} \Sigma^{\dot{a}} \tilde{\Sigma}^{\dot{b}} \right),$$

$$Y^a Y^b Y^c |V\rangle_f \leftrightarrow - \left(\frac{\alpha_{123}}{2} \right)^{\frac{3}{2}} u_{abc}^{i\dot{a}} (\Sigma^{\dot{a}} \tilde{\Sigma}^i + i \Sigma^i \tilde{\Sigma}^{\dot{a}}),$$

$$Y^a Y^b Y^c Y^d |V\rangle_f \leftrightarrow \left(\frac{\alpha_{123}}{2} \right)^2 \left(t_{abcd}^{ij} \Sigma^i \tilde{\Sigma}^j + \frac{1}{16} t_{abcd}^{ijkl} \tilde{\gamma}_{\dot{a}\dot{b}}^{ijkl} \Sigma^{\dot{a}} \tilde{\Sigma}^{\dot{b}} \right),$$

$$Y^a Y^b Y^c Y^d Y^e |V\rangle_f \leftrightarrow \left(\frac{\alpha_{123}}{2} \right)^{\frac{5}{2}} \frac{i}{3!} \varepsilon^{abcdefgh} u_{fgh}^{i\dot{a}} (\Sigma^{\dot{a}} \tilde{\Sigma}^i - i \Sigma^i \tilde{\Sigma}^{\dot{a}}),$$

$$Y^a Y^b Y^c Y^d Y^e Y^f |V\rangle_f \leftrightarrow - \left(\frac{\alpha_{123}}{2} \right)^3 \frac{i}{2} \varepsilon^{abcdefgh} \gamma_{gh}^{ij} \left(\Sigma^i \tilde{\Sigma}^j + \frac{1}{4} \tilde{\gamma}_{\dot{a}\dot{b}}^{ij} \Sigma^{\dot{a}} \tilde{\Sigma}^{\dot{b}} \right),$$

$$Y^a Y^b Y^c Y^d Y^e Y^f Y^g |V\rangle_f \leftrightarrow - \left(\frac{\alpha_{123}}{2} \right)^{\frac{7}{2}} \varepsilon^{abcdefgh} \gamma_{h\dot{a}}^i (\Sigma^{\dot{a}} \tilde{\Sigma}^i + i \Sigma^i \tilde{\Sigma}^{\dot{a}}),$$

$$Y^a Y^b Y^c Y^d Y^e Y^f Y^g Y^h |V\rangle_f \leftrightarrow \left(\frac{\alpha_{123}}{2} \right)^4 \varepsilon^{abcdefgh} (\Sigma^i \tilde{\Sigma}^i + \Sigma^{\dot{a}} \tilde{\Sigma}^{\dot{a}}),$$

and

$$Y^{a'} Y^a Y^b Y^c Y^d Y^e Y^f Y^g Y^h |V\rangle_f = 0 \leftrightarrow : \Lambda_+^{a'} (\Sigma^i \tilde{\Sigma}^i + \Sigma^{\dot{a}} \tilde{\Sigma}^{\dot{a}}) := 0.$$

Here, we note various relations of gamma matrices:

$$\begin{aligned}
t_{abcd}^{ijkl} &\equiv \gamma_{[ab}^{[ij} \gamma_{cd]}^{kl]}, \\
t_{abcd}^{ij} &= \frac{1}{4!} \varepsilon^{abcdefgh} t_{efgh}^{ij}, \\
t_{abcd}^{ijkl} &= -\frac{1}{4!} \varepsilon^{abcdefgh} t_{efgh}^{ijkl}, \\
t_{abcd}^{ijkl} &= -\frac{1}{4!} \varepsilon_{ijklmnpq} t_{abcd}^{mnpq}, \\
\varepsilon_{abcdefgh} \delta^{ij} &= \gamma_{[ab}^{ik} \gamma_{cd}^{kl} \gamma_{ef}^{lm} \gamma_{gh]}^{mj}, \\
\gamma_{a\dot{a}}^i \gamma_{b\dot{b}}^j &= \frac{1}{8} \left(\delta_{i,j} \delta_{a,b} \delta_{\dot{a},\dot{b}} + \delta_{a,b} \gamma_{\dot{a}\dot{b}}^{ij} + \delta_{\dot{a},\dot{b}} \gamma_{ab}^{ij} + \frac{1}{2} \delta_{i,j} \gamma_{ab}^{kl} \gamma_{\dot{a}\dot{b}}^{kl} - \gamma_{ab}^{ik} \gamma_{\dot{a}\dot{b}}^{jk} - \gamma_{ab}^{jk} \gamma_{\dot{a}\dot{b}}^{ik} \right) \\
&\quad + \frac{1}{16} \left(\gamma_{ab}^{kl} \gamma_{\dot{a}\dot{b}}^{ijkl} + \gamma_{ab}^{ijkl} \gamma_{\dot{a}\dot{b}}^{kl} - \frac{1}{3!} (\gamma_{ab}^{iklm} \gamma_{\dot{a}\dot{b}}^{jklm} + \gamma_{ab}^{jklm} \gamma_{\dot{a}\dot{b}}^{iklm}) + \frac{1}{4!} \delta_{i,j} \gamma_{ab}^{klmn} \gamma_{\dot{a}\dot{b}}^{klmn} \right), \\
&\quad \vdots
\end{aligned}$$

and define

$$\begin{aligned}
m^{\dot{a}\dot{b}}(Y) &= \delta^{\dot{a}\dot{b}} + \frac{i}{4\alpha_{123}} \gamma_{\dot{a}\dot{b}}^{kl} \gamma_{ab}^{kl} Y^a Y^b - \frac{1}{96\alpha_{123}^2} \gamma_{\dot{a}\dot{b}}^{klmn} \gamma_{ab}^{kl} \gamma_{cd}^{mn} Y^a Y^b Y^c Y^d \\
&\quad - \frac{i}{6!\alpha_{123}^3} \gamma_{\dot{a}\dot{b}}^{kl} \gamma_{ab}^{kl} \varepsilon^{abcdefgh} Y^c Y^d Y^e Y^f Y^g Y^h \\
&\quad - \frac{2}{7!\alpha_{123}^4} \delta^{\dot{a}\dot{b}} \varepsilon^{abcdefgh} Y^a Y^b Y^c Y^d Y^e Y^f Y^g Y^h.
\end{aligned}$$

Using the above relations, we obtain the correspondence:

$$\begin{aligned}
 |H_1\rangle &\Rightarrow v^{ij}(Y)|V\rangle_f \leftrightarrow 16\Sigma^j\tilde{\Sigma}^i, \\
 |Q_1^{\dot{a}}\rangle &\Rightarrow s^{i\dot{a}}(Y)|V\rangle_f \leftrightarrow 16|\alpha_{123}|^{\frac{1}{2}}\eta^*\Sigma^{\dot{a}}\tilde{\Sigma}^i, \\
 |\tilde{Q}_1^{\dot{a}}\rangle &\Rightarrow \tilde{s}^{i\dot{a}}(Y)|V\rangle_f \leftrightarrow 16|\alpha_{123}|^{\frac{1}{2}}\eta^*\Sigma^i\tilde{\Sigma}^{\dot{a}}, \\
 &m^{\dot{a}\dot{b}}(Y)|V\rangle_f \leftrightarrow -16\Sigma^{\dot{a}}\tilde{\Sigma}^{\dot{b}}.
 \end{aligned}$$

Combing the boson and fermion part, we have

$$\begin{aligned}
 |H_1\rangle &\leftrightarrow \tau^i\Sigma^i\tilde{\tau}^j\tilde{\Sigma}^j, \\
 |Q_1^{\dot{a}}\rangle &\leftrightarrow \sigma\Sigma^{\dot{a}}\tilde{\tau}^i\tilde{\Sigma}^i, \\
 |\tilde{Q}_1^{\dot{a}}\rangle &\leftrightarrow \tau^i\Sigma^i\tilde{\sigma}\tilde{\Sigma}^{\dot{a}}.
 \end{aligned}$$

(LCSFT)

$\alpha_1, \alpha_2, \alpha_3$: fix

without level matching projection

(MST)

$(n, m), z, \bar{z}, N$: fix

SUSY algebra in MST

Free Hamiltonian and super charge
for $(X^i, \theta^a, \tilde{\theta}^a)$:

$$H_0 = \frac{1}{2}(L_0 + \bar{L}_0 - 1),$$

$$L_0 = -\frac{1}{2} \oint \frac{dz}{2\pi i} z (\partial X^i \partial X^i + \theta^a \partial \theta^a),$$

$$\bar{L}_0 = -\frac{1}{2} \oint \frac{d\bar{z}}{2\pi i} \bar{z} (\bar{\partial} X^i \bar{\partial} X^i + \tilde{\theta}^a \bar{\partial} \tilde{\theta}^a),$$

$$Q_0^{\dot{a}} = \oint \frac{dz}{2\pi i} z^{\frac{1}{2}} \gamma_{a\dot{a}}^i \theta^a i \partial X^i(z),$$

$$\tilde{Q}_0^{\dot{a}} = \oint \frac{d\bar{z}}{2\pi i} \bar{z}^{\frac{1}{2}} \gamma_{a\dot{a}}^i \tilde{\theta}^a i \bar{\partial} X^i(\bar{z}),$$

which satisfy

$$\{Q_0^{\dot{a}}, Q_0^{\dot{b}}\} = 2\delta^{\dot{a}\dot{b}} H_0 + \delta^{\dot{a}\dot{b}} (L_0 - \bar{L}_0),$$

$$\{\tilde{Q}_0^{\dot{a}}, \tilde{Q}_0^{\dot{b}}\} = 2\delta^{\dot{a}\dot{b}} H_0 - \delta^{\dot{a}\dot{b}} (L_0 - \bar{L}_0),$$

$$\{Q_0^{\dot{a}}, \tilde{Q}_0^{\dot{b}}\} = 0, \quad [Q_0^{\dot{a}}, H_0] = 0, \quad [\tilde{Q}_0^{\dot{a}}, H_0] = 0.$$

From the correspondence, we define

$$\begin{aligned}
 H_1 &= \int \frac{d\sigma}{2\pi} \tau^i \Sigma^i \tilde{\tau}^j \tilde{\Sigma}^j(\sigma) = \oint \frac{dz}{2\pi i} z^{\frac{1}{2}} \bar{z}^{\frac{3}{2}} \tau^i \Sigma^i \tilde{\tau}^j \tilde{\Sigma}^j(z, \bar{z}), \\
 Q_1^{\dot{a}} &= \sqrt{2} \int \frac{d\sigma}{2\pi} \sigma \Sigma^{\dot{a}} \tilde{\tau}^i \tilde{\Sigma}^i(\sigma) = -\sqrt{2}\eta \oint \frac{dz}{2\pi} \bar{z}^{\frac{3}{2}} \sigma \Sigma^{\dot{a}} \tilde{\tau}^i \tilde{\Sigma}^i(z, \bar{z}), \\
 \tilde{Q}_1^{\dot{a}} &= i\sqrt{2} \int \frac{d\sigma}{2\pi} \tau^i \Sigma^i \tilde{\sigma} \tilde{\Sigma}^{\dot{a}}(\sigma) = -\sqrt{2}\eta \oint \frac{d\bar{z}}{2\pi} z^{\frac{3}{2}} \tau^i \Sigma^i \tilde{\sigma} \tilde{\Sigma}^{\dot{a}}(z, \bar{z}).
 \end{aligned}$$

Using the OPE such as

$$\begin{aligned}
 i\partial X^i(z) \tau^j(0) &\sim z^{-\frac{3}{2}} \frac{\delta^{i,j}}{2} \sigma(0) + z^{-\frac{1}{2}} \tau^{ij}(0), \\
 \theta^a(z) \Sigma^i(0) &\sim z^{-\frac{1}{2}} \frac{\eta^*}{\sqrt{2}} \gamma_{a\dot{a}}^i \Sigma^{\dot{a}}(0) + z^{\frac{1}{2}} \frac{\eta^*}{\sqrt{2}} \left(\frac{5}{3} \gamma_{a\dot{a}}^i \partial \Sigma^{\dot{a}}(0) - \frac{1}{3} \gamma_{a\dot{a}}^k \text{:} \Sigma^i \Sigma^k \text{:} \Sigma^{\dot{a}} \text{:}(0) \right), \\
 &\vdots
 \end{aligned}$$

we have [Moriyama]

$$\begin{aligned}
 \{Q_0^{\dot{a}}, Q_1^{\dot{b}}\} + \{Q_1^{\dot{a}}, Q_0^{\dot{b}}\} &= 2\delta^{\dot{a}\dot{b}} H_1, \\
 \{\tilde{Q}_0^{\dot{a}}, \tilde{Q}_1^{\dot{b}}\} + \{\tilde{Q}_1^{\dot{a}}, \tilde{Q}_0^{\dot{b}}\} &= 2\delta^{\dot{a}\dot{b}} H_1, \\
 \{Q_0^{\dot{a}}, \tilde{Q}_1^{\dot{b}}\} + \{Q_1^{\dot{a}}, \tilde{Q}_0^{\dot{b}}\} &= 0, \\
 [Q_0^{\dot{a}}, H_1] + [Q_1^{\dot{a}}, H_0] &= 0, \\
 [\tilde{Q}_0^{\dot{a}}, H_1] + [\tilde{Q}_1^{\dot{a}}, H_0] &= 0.
 \end{aligned} \tag{MST}$$

Contents

- Introduction and summary
- Correspondence between LCSFT and MST
 - Brief review of LCSFT [Green-Schwarz-Brink]
 - Brief review of MST [Dijkgraaf-Verlinde-Verlinde]
 - Review of previous results on the correspondence [Dijkgraaf-Motl], [Moriyama]
- **Contractions in bosonic LCSFT [KMT]**
- **A simple form of the prefactors [KM]**
- **Contractions in super LCSFT [KM]**
- **Conclusion and future directions**

Contractions in bosonic LCSFT

Let us consider the contractions in the *bosonic* LCSFT for simplicity [KMT]. The 3-string vertex is the same form as the bosonic part of Green-Schwarz-Brink's LCSFT *without the prefactor*:

$$|V(1, 2, 3)\rangle = (2\pi)^{25} \delta(\alpha_1 + \alpha_2 + \alpha_3) \delta^{24}(p_1^i + p_2^i + p_3^i) [\mu(\alpha_1, \alpha_2, \alpha_3)]^2 \\ \times e^{\frac{1}{2} \sum \bar{N}_{nm}^{rs} (\alpha_{-n}^{(r)} \alpha_{-n}^{(s)} + \tilde{\alpha}_{-n}^{(r)} \tilde{\alpha}_{-n}^{(s)}) + \sum \bar{N}_n^r (\alpha_{-n}^{(r)} + \tilde{\alpha}_{-n}^{(r)}) P - \frac{\tau_0}{\alpha_{123}} P^2} |0\rangle,$$

where $\mu(\alpha_1, \alpha_2, \alpha_3) = e^{-\tau_0 \sum_{r=1}^3 \alpha_r^{-1}}$.

The reflector (bra, ket) is given by

$$\langle R(1, 2)| = \langle 0| e^{-\sum_n \frac{1}{n} (\alpha_n^{(1)i} \alpha_n^{(2)i} + \tilde{\alpha}_n^{(1)i} \tilde{\alpha}_n^{(2)i})} (2\pi)^{24} \delta^{24}(p_1^i + p_2^i), \\ |R(1, 2)\rangle = (2\pi)^{24} \delta^{24}(p_1^i + p_2^i) e^{-\sum_n \frac{1}{n} (\alpha_{-n}^{(1)i} \alpha_{-n}^{(2)i} + \tilde{\alpha}_{-n}^{(1)i} \tilde{\alpha}_{-n}^{(2)i})} |0\rangle.$$

The reflector can be regarded as “1” in a sense because

$${}_1\langle \Phi| \equiv \langle R(1, 2)| \Phi \rangle_2, \quad \langle R(1, 2)| R(2, 3) \rangle = \text{id}_{3,1}.$$

We expect a correspondence:

$$|V(1, 2, 3)\rangle \leftrightarrow \sigma \tilde{\sigma}$$

$$|R(1, 2)\rangle \leftrightarrow 1$$

We expected that $\sigma\tilde{\sigma}(z, \bar{z})\sigma\tilde{\sigma}(0)$, ($|z| \rightarrow 0$) corresponds to

$$\langle R(3,6) | e^{-\frac{T}{|\alpha_3|}(L_0^{(3)} + \tilde{L}_0^{(3)})} | V(1_{\alpha_1}, 2_{\alpha_2}, 3_{\alpha_3}) \rangle | V(4_{-\alpha_1}, 5_{-\alpha_2}, 6_{-\alpha_3}) \rangle \quad (\text{tree})$$

or

$$\langle R(2,5) | \langle R(1,4) | e^{-\frac{T}{\alpha_1}(L_0^{(1)} + \tilde{L}_0^{(1)}) - \frac{T}{\alpha_2}(L_0^{(2)} + \tilde{L}_0^{(2)})} | V(1_{\alpha_1}, 2_{\alpha_2}, 3_{\alpha_3}) \rangle | V(4_{-\alpha_1}, 5_{-\alpha_2}, 6_{-\alpha_3}) \rangle$$

(1-loop) with $T \sim |z|$.

We fix α_r ($\alpha_4 = -\alpha_1, \alpha_5 = -\alpha_2$) and do not insert the level matching projection.

At least formally, computation of the above quantities can be performed because the reflector and the 3-string vertex are Gaussian form with respect to the oscillators. For $T = 0$, using the quadratic relations among the Neumann coefficients:

$$\sum_{l,t} \bar{N}_{nl}^{rt} l \bar{N}_{lm}^{ts} = n^{-1} \delta^{nm} \delta^{rs}, \quad \sum_{l,t} \bar{N}_{nl}^{rt} l \bar{N}_l^t = -\bar{N}_n^r, \quad \sum_{l,t} \bar{N}_l^t l \bar{N}_l^t = (\alpha_{123})^{-1} 2\tau_0$$

we have $\langle R|V\rangle|V\rangle \propto |R\rangle|R\rangle$, $\langle R|\langle R|V\rangle|V\rangle \propto |R\rangle$

with divergent coefficients given by the determinant of the Neumann matrices.

In **the contraction (tree)** with $T \neq 0$,
 we have the determinant factor of the Neumann coefficients from *nonzero modes*,
 which was evaluated using Cremmer-Gervais identity: [I.K.-Matsuo-Watanabe2]

$$\left| [\mu(\alpha_1, \alpha_2, \alpha_3)]^2 \det^{-12} (1 - \tilde{N}_{T/2}^{33} \tilde{N}_{T/2}^{33}) \right|^2 \sim 2^{10} \left[\frac{T}{|\alpha_{123}|^{1/3}} \right]^{-6},$$

for $T \rightarrow +0$, where $(\tilde{N}_{T/2}^{33})_{nm} = e^{-\frac{n+m}{2|\alpha_3|}T} \sqrt{nm} \bar{N}_{nm}^{33}$.

From *zero mode*, we have a logarithmic factor:

$$e^{-b_T(p_1+p_4)^2} \sim \left[\frac{\pi}{2 \log(|\alpha_3|/T)} \right]^{12} \delta^{24}(p_1 + p_4), \quad (T \rightarrow +0),$$

which we have evaluated using the Mandelstam map:

$$b_T = \alpha_3^2 \sum_{n,m \geq 1} \sqrt{nm} e^{-\frac{n+m}{2|\alpha_3|}T} \bar{N}_n^3 \bar{N}_m^3 \left[(1 - \tilde{N}_{T/2}^{33} \tilde{N}_{T/2}^{33})^{-1} \right]_{nm} = -\log(1 - Z_5),$$

$$\rho(z) = \alpha_1 \log(z - Z_\infty) + \alpha_2 \log(z - 1) - \alpha_2 \log(z - Z_5) - \alpha_1 \log z, \quad (Z_\infty \rightarrow \infty),$$

$$T = \rho(z_+) - \rho(z_-), \quad \frac{d\rho}{dz}(z_\pm) = 0.$$

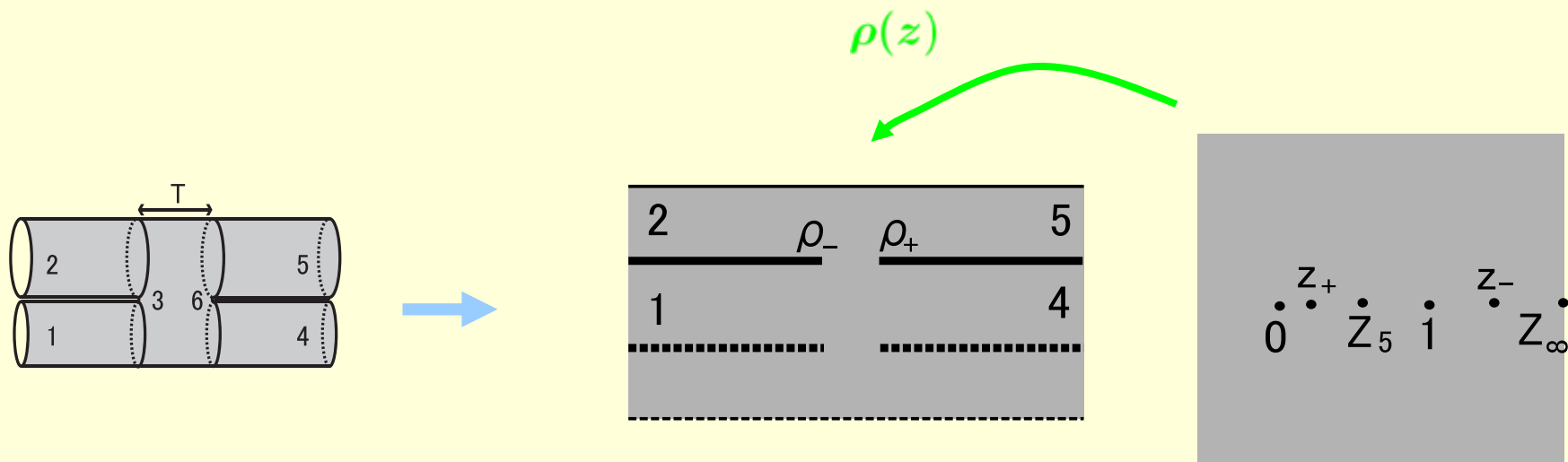

The result is

$$\langle R(3, 6) | e^{-\frac{T}{|\alpha_3|} (L_0^{(3)} + \tilde{L}_0^{(3)})} | V(1_{\alpha_1}, 2_{\alpha_2}, 3_{\alpha_3}) \rangle | V(4_{-\alpha_1}, 5_{-\alpha_2}, 6_{-\alpha_3}) \rangle$$

$$\sim 2^{-26} \pi^{-12} \left[\frac{T}{|\alpha_{123}|^{1/3}} \left(\log \frac{T}{|\alpha_{123}|^{1/3}} \right)^2 \right]^{-6} | R(1, 4) \rangle | R(2, 5) \rangle .$$

In the contraction **(1-loop)** with $T \neq 0$, similar calculation manipulating the Neumann coefficients seems to be difficult. Instead, we have used $\alpha = p^+$ HIKKO formulation with LPP vertex to evaluate the determinant factor. Namely, comparing the expression of

$${}_3\langle -k_3 | {}_6\langle -k_6 | \langle R(2, 5) | \langle R(1, 4) | \Delta_1 \Delta_2 | V(1, 2, 3) \rangle | V(4, 5, 6) \rangle$$

($\Delta_{1,2}$: propagator) for LCSFT and $\alpha = p^+$ HIKKO SFT, we evaluate the factor by computing CFT correlator on the torus:

$$\left\langle b_{T_1} \tilde{b}_{T_1} b_{T_2} \tilde{b}_{T_2} c \tilde{c} e^{ik_3 X}(U_3) c \tilde{c} e^{ik_6 X}(U_6) \right\rangle_{\tau},$$

where $b_{T_1} = \int_{C_1} du \left(\frac{d\rho}{du} \right)^{-1} b(u), \dots$ and the generalized Mandelstam map is given by

$$\begin{aligned} \rho(u) &= |\alpha_3| (\log \vartheta_1(u - U_6 | \tau) - \log \vartheta_1(u - U_3 | \tau)) - 2\pi i \alpha_1 u, \\ T &= \rho(u_-) - \rho(u_+), \quad \frac{d\rho}{du}(u_{\pm}) = 0. \end{aligned}$$

For $T \rightarrow +0$, the modulus τ , which is pure imaginary, is given by [I.K.-Matsuo2]

$$e^{-\frac{i\pi}{\tau}} \sim \frac{T}{8|\alpha_3| \sin(\pi\alpha_1/|\alpha_3|)}.$$

In computation of the correlator, we evaluate residue at the interaction points u_{\pm} for ghost sector and treat $\alpha = p^+$ carefully. [Asakawa-Kugo-Takahashi]

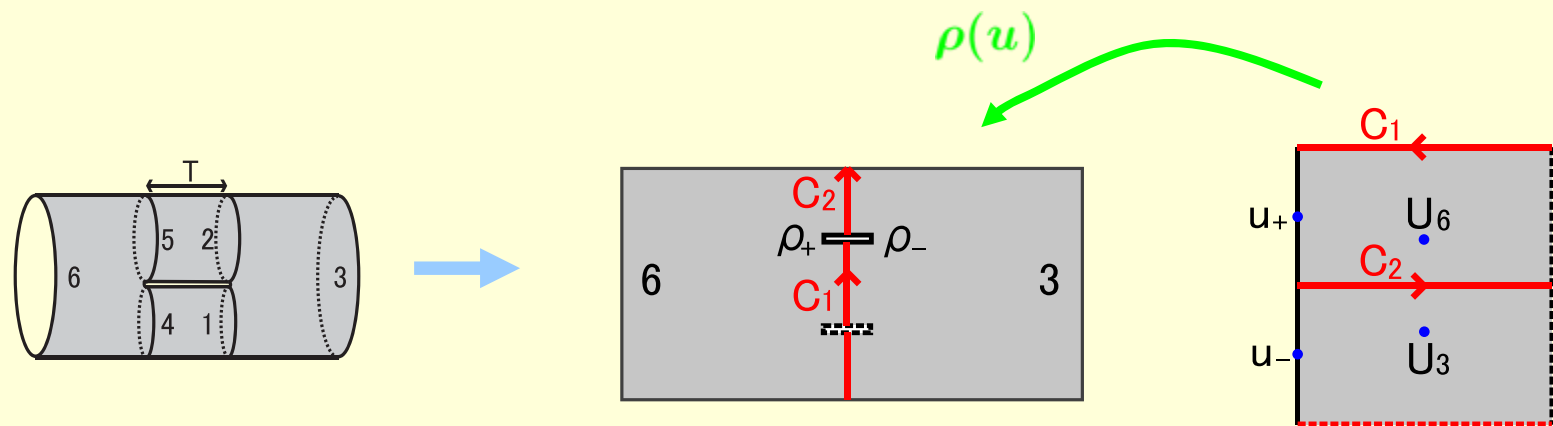

The result is

$$\langle R(2,5) | \langle R(1,4) | e^{-\frac{T}{\alpha_1}(L_0^{(1)} + \tilde{L}_0^{(1)}) - \frac{T}{\alpha_2}(L_0^{(2)} + \tilde{L}_0^{(2)})} | V(1_{\alpha_1}, 2_{\alpha_2}, 3_{\alpha_3}) \rangle | V(4_{-\alpha_1}, 5_{-\alpha_2}, 6_{-\alpha_3}) \rangle \rangle$$

$$\sim 2^{-13} \pi^{-12} \left[\frac{T}{|\alpha_{123}|^{1/3}} \left(\log \frac{T}{|\alpha_{123}|^{1/3}} \right)^2 \right]^{-6} | R(3,6) \rangle .$$

On the other hand (MST side), a CFT correlator of \mathbb{Z}_2 twist fields for \mathbb{R}^D behaves as

$$\langle \sigma \tilde{\sigma}(\infty) \sigma \tilde{\sigma}(1) \sigma \tilde{\sigma}(z, \bar{z}) \sigma \tilde{\sigma}(0) \rangle \sim \left[|z|^{-1} (\log |z|)^{-2} \right]^{\frac{D}{4}}$$

for $|z| \sim 0$. [Dixon-Friedan-Martinec-Shenker], [Okawa-Zwiebach]

Note: the modulus τ of the associated torus becomes $e^{-\frac{i\pi}{\tau}} \sim \frac{|z|}{16}$ for $z \in \mathbb{R}$, $|z| \rightarrow 0$.



If we identify $T \sim |z|$ and take $D = d - 2 = 24$,
singular behavior of contraction of the 3-string vertices is consistent with:

$$|V(1, 2, 3)\rangle \leftrightarrow \sigma \tilde{\sigma}$$

$$|R(1, 2)\rangle \leftrightarrow 1$$

A simple form of the prefactors

Noting the triality of $SO(8)$, let us define new gamma matrix:

$$\hat{\gamma}^a = (\hat{\gamma}^a)_{(i,\dot{a}), (j,\dot{b})} = \begin{pmatrix} 0 & \gamma_{ab}^i \\ \gamma_{a\dot{a}}^j & 0 \end{pmatrix}, \quad \hat{\gamma}^a \hat{\gamma}^b + \hat{\gamma}^b \hat{\gamma}^a = 2\delta^{ab} \mathbf{1}_{16}.$$

Then, the prefactors given by GSB can be rewritten as [KM]

$$\begin{aligned} e^{\mathcal{Y}} = [e^{\mathcal{Y}}]_{(i,\dot{a}), (j,\dot{b})} &= \begin{pmatrix} [\cosh \mathcal{Y}]_{ij} & [\sinh \mathcal{Y}]_{i\dot{b}} \\ [\sinh \mathcal{Y}]_{\dot{a}j} & [\cosh \mathcal{Y}]_{\dot{a}\dot{b}} \end{pmatrix} \\ &= \begin{pmatrix} v^{ij}(Y) & i(-\alpha_{123})^{-\frac{1}{2}} s^{i\dot{b}}(Y) \\ (-\alpha_{123})^{-\frac{1}{2}} \tilde{s}^{j\dot{a}}(Y) & m^{\dot{b}\dot{a}}(Y) \end{pmatrix}, \end{aligned}$$

$$\mathcal{Y} \equiv y_0 Y^a \hat{\gamma}^a \equiv \left(\frac{2}{-\alpha_{123}} \right)^{\frac{1}{2}} \eta Y^a \hat{\gamma}^a, \quad \mathcal{Y}^9 = 0.$$

Using a relation, $f(\mathcal{Y})\hat{\gamma}^a = (-1)^{|f|}\hat{\gamma}^a f(\mathcal{Y}) - (-1)^{|f|}2y_0\mathcal{Y}^a f'(\mathcal{Y})$

and the Fierz identity

$$M_{AB}N_{CD} = (-1)^{|M||N|}2^{-4} \sum_{k=0}^8 \frac{(-1)^{\frac{1}{2}k(k-1)}}{k!} \hat{\gamma}_{AD}^{a_1 \dots a_k} (N \hat{\gamma}^{a_1 \dots a_k} M)_{CB}.$$

We can easily check the SUSY algebra:

$$\sum_{r=1}^3 Q_0^{\dot{a}(r)} |Q_1^{\dot{b}}\rangle + \sum_{r=1}^3 Q_0^{\dot{b}(r)} |Q_1^{\dot{a}}\rangle = \sum_{r=1}^3 \tilde{Q}_0^{\dot{a}(r)} |\tilde{Q}_1^{\dot{b}}\rangle + \sum_{r=1}^3 \tilde{Q}_0^{\dot{b}(r)} |\tilde{Q}_1^{\dot{a}}\rangle = 2|H_1\rangle \delta^{\dot{a}\dot{b}},$$

$$\sum_{r=1}^3 Q_0^{\dot{a}(r)} \mathcal{P}_{123} |\tilde{Q}_1^{\dot{b}}\rangle + \sum_{r=1}^3 \tilde{Q}_0^{\dot{b}(r)} \mathcal{P}_{123} |Q_1^{\dot{a}}\rangle = 0.$$

For example,
$$\sum_r Q_0^{\dot{a}(r)} \tilde{Z}^i [\tilde{f}(\mathcal{Y})]_{i\dot{b}} |V\rangle + \sum_r Q_0^{\dot{b}(r)} \tilde{Z}^i [\tilde{f}(\mathcal{Y})]_{i\dot{a}} |V\rangle$$

$$= 2 \left(\frac{i}{\sqrt{-\alpha_{123}}} \delta_{\dot{a}\dot{b}} \tilde{Z}^i Z^j \left[\tilde{f}'(\mathcal{Y}) + \frac{1}{8} (\tilde{f}(\mathcal{Y}) - \tilde{f}''(\mathcal{Y})) \mathcal{Y} \right]_{ij} \right. \\ \left. + \frac{i}{\sqrt{-\alpha_{123}}} \frac{1}{16 \cdot 4!} \hat{\gamma}_{\dot{a}\dot{b}}^{abcd} \tilde{Z}^i Z^j \left[(\tilde{f}(\mathcal{Y}) - \tilde{f}''(\mathcal{Y})) \hat{\gamma}^{abcd} \mathcal{Y} \right]_{ij} \right) |V\rangle,$$

with $\tilde{f}(\mathcal{Y}) = -i\sqrt{-\alpha_{123}} \sinh \mathcal{Y}.$

The Fourier transformation of the prefactors in the fermionic sector is

$$\begin{pmatrix} [\cosh \mathcal{Y}]_{ij} & [\sinh \mathcal{Y}]_{ib} \\ [\sinh \mathcal{Y}]_{\dot{a}j} & [\cosh \mathcal{Y}]_{\dot{a}\dot{b}} \end{pmatrix} = \frac{\alpha_{123}^4}{16} \int d^8 \phi \begin{pmatrix} [\cosh \phi]_{ji} & -i[\sinh \phi]_{bi} \\ i[\sinh \phi]_{j\dot{a}} & -[\cosh \phi]_{\dot{a}\dot{b}} \end{pmatrix} e^{\frac{2}{\alpha_{123}} \phi^a \mathcal{Y}^a}.$$

This form is useful for concrete calculation of contractions.

The (expected) correspondence in the *fermionic sector* can be rewritten as

$$\begin{pmatrix} [\cosh \mathcal{Y}]_{ij} & [\sinh \mathcal{Y}]_{ib} \\ [\sinh \mathcal{Y}]_{\dot{a}j} & [\cosh \mathcal{Y}]_{\dot{a}\dot{b}} \end{pmatrix} |V\rangle_f \leftrightarrow 16 \begin{pmatrix} -\tilde{\Sigma}^i \Sigma^j & \eta \tilde{\Sigma}^i \Sigma^{\dot{b}} \\ \eta^* \tilde{\Sigma}^{\dot{a}} \Sigma^j & -\tilde{\Sigma}^{\dot{a}} \Sigma^{\dot{b}} \end{pmatrix}$$

(LCSFT)

(MST)

Contractions in super LCSFT

Let us consider contractions in the *fermionic sector*. [KM]

The 3-string vertex with prefactors is essentially written by

$$e^{\frac{2}{\alpha_{123}} \phi^a Y^a} |V(1, 2, 3)\rangle_f = \delta^8(\lambda_1^a + \lambda_2^a + \lambda_3^a) e^{\frac{2}{\alpha_{123}} \phi^a \Lambda^a} \\ \times e^{\sum Q_{-n}^{II(r)} \alpha_r^{-1} n \bar{N}_{nm}^{rs} Q_{-m}^{I(s)} - \sqrt{2} \sum \alpha_r^{-1} n \bar{N}_n^r (\phi Q_{-n}^{I(r)} + \Lambda Q_{-n}^{II(r)})} |0\rangle.$$

The reflector for fermions:

$$\langle R(1, 2)| = \langle 0| e^{\frac{2}{\alpha_1 - \alpha_2} \sum_{n=1}^{\infty} (Q_n^{I(1)} Q_n^{II(2)} - Q_n^{I(2)} Q_n^{II(1)})} \delta^8(\lambda^{(1)} + \lambda^{(2)}) \\ |R(1, 2)\rangle = \delta^8(\lambda^{(1)} + \lambda^{(2)}) e^{\frac{2}{\alpha_1 - \alpha_2} \sum_{n=1}^{\infty} (-Q_{-n}^{I(1)} Q_{-n}^{II(2)} + Q_{-n}^{I(2)} Q_{-n}^{II(1)})} |0\rangle$$

For fermionic oscillators such as $\{a, a^\dagger\} = 1$, we have a formula

$$e^{\frac{1}{2} a M a + \lambda a} e^{\frac{1}{2} a^\dagger N a^\dagger + \mu a^\dagger} |0\rangle \\ = \det^{\frac{1}{2}}(1 + MN) e^{\frac{1}{2} \lambda N (1 + MN)^{-1} \lambda + \frac{1}{2} \mu (1 + MN)^{-1} M \mu + \mu (1 + MN)^{-1} \lambda} \\ \times e^{(\mu + \lambda N)(1 + MN)^{-1} a^\dagger + \frac{1}{2} a^\dagger N (1 + MN)^{-1} a^\dagger} |0\rangle.$$

(M, N : anti-symmetric matrices)

We find that both

$$\langle R(3, 6) | e^{-\frac{\tau}{|\alpha_3|} (L_0^{(3)} + \tilde{L}_0^{(3)})} e^{\frac{2}{\alpha_{123}} \phi_{123}^\alpha Y_{123}^\alpha} | V(1_{\alpha_1}, 2_{\alpha_2}, 3_{\alpha_3}) \rangle_f e^{-\frac{2}{\alpha_{123}} \phi_{456}^\alpha Y_{456}^\alpha} | V(4_{-\alpha_1}, 5_{-\alpha_2}, 6_{-\alpha_3}) \rangle_f \quad (\text{tree})$$

and

$$\langle R(2, 5) | \langle R(1, 4) | e^{-\frac{\tau}{\alpha_1} (L_0^{(1)} + \tilde{L}_0^{(1)}) - \frac{\tau}{\alpha_2} (L_0^{(2)} + \tilde{L}_0^{(2)})} \times e^{\frac{2}{\alpha_{123}} \phi_{123}^\alpha Y_{123}^\alpha} | V(1_{\alpha_1}, 2_{\alpha_2}, 3_{\alpha_3}) \rangle_f e^{-\frac{2}{\alpha_{123}} \phi_{456}^\alpha Y_{456}^\alpha} | V(4_{-\alpha_1}, 5_{-\alpha_2}, 6_{-\alpha_3}) \rangle_f \quad (\text{1-loop})$$

are **not** of the form $e^{\phi^{\dots} (\dots)_{ab} \phi^b + \dots} | 0 \rangle$.

Therefore, schematically, the contractions in the fermionic sector are computed as

$$\langle R(3, 6) | e^{-\frac{\tau}{|\alpha_3|} (L_0^{(3)} + \tilde{L}_0^{(3)})} f(\mathcal{Y}_{123}) | V(1_{\alpha_1}, 2_{\alpha_2}, 3_{\alpha_3}) \rangle_f g(\mathcal{Y}_{456}) | V(4_{-\alpha_1}, 5_{-\alpha_2}, 6_{-\alpha_3}) \rangle_f \\ = \delta^8(\lambda_1 + \lambda_2 + \lambda_4 + \lambda_5) \det^8(1 - (\tilde{N}_{T/2}^{33})^2) f(\mathcal{Y}'_{123}) g(\mathcal{Y}'_{456}) e^{F_T(1,2,4,5)} | 0 \rangle$$

and

$$\langle R(2, 5) | \langle R(1, 4) | e^{-\frac{\tau}{\alpha_1} (L_0^{(1)} + \tilde{L}_0^{(1)}) - \frac{\tau}{\alpha_2} (L_0^{(2)} + \tilde{L}_0^{(2)})} \times f(\mathcal{Y}_{123}) | V(1_{\alpha_1}, 2_{\alpha_2}, 3_{\alpha_3}) \rangle_f g(\mathcal{Y}_{456}) | V(4_{-\alpha_1}, 5_{-\alpha_2}, 6_{-\alpha_3}) \rangle_f \\ = \delta^8(\lambda_3 + \lambda_6) \det^8(1 - (\tilde{N}_{T/2}^{(12)(12)})^2) \int d^8 \lambda_1 f(\mathcal{Y}'_{123}) g(\mathcal{Y}'_{456}) e^{F_T(3,6,\lambda_1)} | 0 \rangle$$

where $f(x), g(x) = \cosh x$ or $\sinh x$.

Here, $\mathbf{y}_{123}^a \sim -\mathbf{y}_{456}^a \sim -\mathcal{C}_{1,T}\alpha_3(\lambda_2 + \lambda_5)^a$ (tree)

$$\vdots$$

$$\mathcal{C}_{1,T} = \alpha_{123}\tilde{N}_{T/2}^3 \frac{C}{\alpha_3} (1 - (\tilde{N}_{T/2}^{33})^2)^{-1} \tilde{N}_{T/2}^3 \sim \sqrt{\frac{2\alpha_1\alpha_2}{|\alpha_3|T}},$$

$$C_{nm} = n\delta_{n,m}, \quad (\tilde{N}_{T/2}^3)_n = \sqrt{n}\bar{N}_n^3 e^{-\frac{nT}{|\alpha_3|}}, \quad (\tilde{N}_{T/2}^{33})_{nm} = e^{-\frac{nT}{|\alpha_3|}} \sqrt{nm}\bar{N}_{nm}^{33} e^{-\frac{mT}{|\alpha_3|}}$$

$$\vdots$$

and

$$\mathbf{y}'_{123}{}^a \sim \mathbf{y}'_{456}{}^a \sim -2\mathcal{C}_{1',T}\alpha_3(\lambda_1 - \alpha_1\lambda_3/\alpha_3)^a$$
 (1-loop)
$$\vdots$$

$$\mathcal{C}_{1',T} = \alpha_{123}\tilde{N}_{T/2}^{(12)} \frac{C}{\alpha_{(12)}} (1 - (\tilde{N}_{T/2}^{(12)(12)})^2)^{-1} \tilde{N}_{T/2}^{(12)} \sim \frac{g_2}{2} T^{-\frac{1}{2}} \left(\log \frac{T}{|\alpha_3|} \right)^{-1},$$

$$(\tilde{N}_{T/2}^{(12)})_n = \sqrt{n}\bar{N}_n^{(12)} e^{-\frac{nT}{\alpha_{(12)}}}, \quad (\tilde{N}_{T/2}^{(12)(12)})_{nm} = e^{-\frac{nT}{\alpha_{(12)}}} \sqrt{nm}\bar{N}_{nm}^{(12)(12)} e^{-\frac{mT}{\alpha_{(12)}}}$$

$$\vdots$$

Noting $\alpha_{456} = -\alpha_{123}$,

$$[\cosh(i\mathcal{Y}) + \sinh(i\mathcal{Y})] = [\cosh\mathcal{Y} + i \sinh\mathcal{Y}]^T,$$

we evaluated the prefactors by the Fierz transformation such as:

$$[\cosh\mathcal{Y}]_{ij}[\cosh\mathcal{Y}]_{lk} = 2^{-4} \sum_{p=0}^4 \frac{(-1)^p}{(2p)!} \hat{\gamma}_{ik}^{a_1 \dots a_{2p}} (\cosh\mathcal{Y} \hat{\gamma}^{a_1 \dots a_{2p}} \cosh\mathcal{Y})_{lj}$$

$$= 16\delta_{ik}\delta_{jl} \left(\frac{2}{\alpha_{123}} \right)^4 \delta^8(Y) + \mathcal{O}(Y^6),$$

$$[\sinh\mathcal{Y}]_{i\dot{a}}[\sinh\mathcal{Y}]_{\dot{b}j} = -2^{-4} \sum_{p=0}^4 \frac{(-1)^p}{(2p)!} \hat{\gamma}_{ik}^{a_1 \dots a_{2p}} (\sinh\mathcal{Y} \hat{\gamma}^{a_1 \dots a_{2p}} \sinh\mathcal{Y})_{\dot{b}\dot{a}}$$

$$= 16\delta_{ij}\delta_{\dot{a}\dot{b}} \left(\frac{2}{\alpha_{123}} \right)^4 \delta^8(Y) + \mathcal{O}(Y^6),$$

$$[\cosh\mathcal{Y}]_{ij}[\sinh\mathcal{Y}]_{\dot{a}k} = 2^{-4} \sum_{p=0}^4 \frac{(-1)^p}{(2p)!} \hat{\gamma}_{ik}^{a_1 \dots a_{2p}} (\sinh\mathcal{Y}_{123} \hat{\gamma}^{a_1 \dots a_{2p}} \cosh\mathcal{Y}_{123})_{\dot{a}j}$$

$$= -8\eta^* \delta_{ik} \left(\frac{2}{|\alpha_{123}|} \right)^{\frac{7}{2}} \gamma_{c\dot{a}}^j \frac{\partial}{\partial Y^c} \delta^8(Y) + \mathcal{O}(Y^5),$$

⋮

- Small T behavior of the Neumann matrix products

From the structure of Neumann coefficients, the following identities hold: [Cremmer-Gervais,HIKKO2]

$$\bar{a}_{ij} \equiv \alpha_1 \alpha_2 \tilde{N}_{T/2}^3 C^i \tilde{N}_{T/2}^{33} \left(1 - (\tilde{N}_{T/2}^{33})^2\right)^{-1} C^j \tilde{N}_{T/2}^3, \quad (i, j \geq 0) \quad (\text{tree})$$

$$\bar{b}_{ij} \equiv \alpha_1 \alpha_2 \tilde{N}_{T/2}^3 C^i \left(1 - (\tilde{N}_{T/2}^{33})^2\right)^{-1} C^j \tilde{N}_{T/2}^3, \quad (i, j \geq 0)$$

$$|\alpha_3| \frac{\partial}{\partial T} \log \det(1 - (\tilde{N}_{T/2}^{33})^2) = -\bar{a}_{11},$$

$$|\alpha_3| \frac{\partial}{\partial T} \bar{a}_{ij} = \bar{b}_{1i} \bar{b}_{1j},$$

$$|\alpha_3| \frac{\partial}{\partial T} \bar{b}_{ij} = \bar{b}_{i1} \bar{a}_{1j} - \bar{b}_{i,j+1}.$$

Similarly, we can derive the following identities for (1-loop) :

$$a_{ij} \equiv \alpha_3^2 \tilde{N}_{T/2}^{(12)} \left(\frac{C}{\alpha_{(12)}}\right)^i \tilde{N}_{T/2}^{(12)(12)} \left(1 - (\tilde{N}_{T/2}^{(12)(12)})^2\right)^{-1} \left(\frac{C}{\alpha_{(12)}}\right)^j \tilde{N}_{T/2}^{(12)},$$

$$b_{ij} \equiv \alpha_3^2 \tilde{N}_{T/2}^{(12)} \left(\frac{C}{\alpha_{(12)}}\right)^i \left(1 - (\tilde{N}_{T/2}^{(12)(12)})^2\right)^{-1} \left(\frac{C}{\alpha_{(12)}}\right)^j \tilde{N}_{T/2}^{(12)},$$

$$\frac{\partial}{\partial T} \log \det(1 - (\tilde{N}_{T/2}^{(12)(12)})^2) = -\frac{\alpha_1 \alpha_2}{\alpha_3} a_{11},$$

$$\frac{\partial}{\partial T} a_{ij} = \frac{\alpha_1 \alpha_2}{\alpha_3} b_{i1} b_{1j},$$

$$\frac{\partial}{\partial T} b_{ij} = \frac{\alpha_1 \alpha_2}{\alpha_3} b_{i1} a_{1j} - b_{i,j+1}.$$

From the result in the bosonic LCSFT [KMT], we can read off the leading behavior of the determinants:

$$\det(1 - (\tilde{N}_{T/2}^{33})^2) = 2^{-\frac{5}{12}}(-\beta)^{\frac{1}{12}-\frac{1}{6}\left(1+\beta+\frac{1}{1+\beta}\right)}(1+\beta)^{\frac{1}{12}+\frac{1}{6}\left(\beta+\frac{1}{\beta}\right)}\left(\frac{T}{|\alpha_3|}\right)^{\frac{1}{4}} + \dots,$$

$$\bar{b}_{00} = 2(-\beta)(1+\beta)\log\frac{|\alpha_3|}{T} + \dots, \quad (\text{tree})$$

$$\det(1 - (\tilde{N}_{T/2}^{(12)(12)})^2)(c_T)^{\frac{1}{2}}$$

$$= 2^{-\frac{11}{24}}(-\beta)^{\frac{1}{12}-\frac{1}{6}\left(1+\beta+\frac{1}{1+\beta}\right)}(1+\beta)^{\frac{1}{12}+\frac{1}{6}\left(\beta+\frac{1}{\beta}\right)}\left[\frac{T}{|\alpha_3|}\left(\log\frac{T}{|\alpha_3|}\right)^2\right]^{\frac{1}{4}} + \dots,$$

$$c_T = \log\left((- \beta)^{-\frac{2}{1+\beta}}(1+\beta)^{\frac{2}{\beta}}\right) - 2(a_{00} + b_{00}), \quad (\text{1-loop})$$

for $T \rightarrow +0$.

Using the above data and exact identities for $T=0$ [Green-Schwarz], we can solve some “differential equations” and evaluate the contractions.

The results are

“ $H_1 H_1$ ”: (LCSFT)

$$\langle R | e^{-\frac{T}{|\alpha_3|}(L_0^{(3)} + \tilde{L}_0^{(3)})} [\cosh \mathcal{Y}]_{ij} | V \rangle [\cosh \mathcal{Y}]_{kl} | V \rangle \sim \delta^{ik} \delta^{jl} T^{-2} | R \rangle | R \rangle$$

$$\langle R | \langle R | e^{-\frac{T}{\alpha_1}(L_0^{(1)} + \tilde{L}_0^{(1)})} e^{-\frac{T}{\alpha_2}(L_0^{(2)} + \tilde{L}_0^{(2)})} [\cosh \mathcal{Y}]_{ij} | V \rangle [\cosh \mathcal{Y}]_{kl} | V \rangle \sim \delta^{ik} \delta^{jl} T^{-2} | R \rangle$$

$$\longleftrightarrow \quad \Sigma^j \tilde{\Sigma}^i(z, \bar{z}) \Sigma^l \tilde{\Sigma}^k(0) \sim \frac{\delta^{ik} \delta^{jl}}{|z|^2} \quad (\text{MST})$$

“ $Q_1^{\dot{a}} Q_1^{\dot{b}}$ ”: (LCSFT)

$$\langle R | e^{-\frac{T}{|\alpha_3|}(L_0^{(3)} + \tilde{L}_0^{(3)})} [\sinh \mathcal{Y}]_{i\dot{a}} | V \rangle [\sinh \mathcal{Y}]_{j\dot{b}} | V \rangle \sim \delta^{ij} \delta^{\dot{a}\dot{b}} T^{-2} | R \rangle | R \rangle$$

$$\langle R | \langle R | e^{-\frac{T}{\alpha_1}(L_0^{(1)} + \tilde{L}_0^{(1)})} e^{-\frac{T}{\alpha_2}(L_0^{(2)} + \tilde{L}_0^{(2)})} [\sinh \mathcal{Y}]_{i\dot{a}} | V \rangle [\sinh \mathcal{Y}]_{j\dot{b}} | V \rangle \sim \delta^{ij} \delta^{\dot{a}\dot{b}} T^{-2} | R \rangle$$

$$\longleftrightarrow \quad \Sigma^{\dot{a}} \tilde{\Sigma}^i(z, \bar{z}) \Sigma^{\dot{b}} \tilde{\Sigma}^j(0) \sim \frac{\delta^{ij} \delta^{\dot{a}\dot{b}}}{|z|^2} \quad (\text{MST})$$

“ $H_1 Q_1^{\dot{a}}$ ”:

$$\langle R | e^{-\frac{T}{|\alpha_3|}(L_0^{(3)} + \tilde{L}_0^{(3)})} [\cosh \mathcal{Y}]_{ij} |V\rangle [\sinh \mathcal{Y}]_{k\dot{a}} |V\rangle$$

$$\sim \delta^{ik} T^{-\frac{3}{2}} \gamma_{c\dot{a}}^j (\vartheta_{(2)}^c - \vartheta_{(1)}^c) (\sigma_{\text{int}}) |R\rangle |R\rangle$$

$$\longleftrightarrow \Sigma^j \tilde{\Sigma}^i(z, \bar{z}) \Sigma^{\dot{a}} \tilde{\Sigma}^k(0) \sim \frac{1}{z^{\frac{1}{2}} \bar{z}} \frac{\delta^{ik}}{\sqrt{2i}} \gamma_{c\dot{a}}^j \theta^c(0)$$

“ $Q_1^{\dot{a}} \tilde{Q}_1^{\dot{b}}$ ”:

$$\langle R | e^{-\frac{T}{|\alpha_3|}(L_0^{(3)} + \tilde{L}_0^{(3)})} [\sinh \mathcal{Y}]_{i\dot{a}} |V\rangle [\sinh \mathcal{Y}]_{\dot{b}j} |V\rangle$$

$$\sim T^{-1} \gamma_{c\dot{a}}^j (\vartheta_{(2)}^c - \vartheta_{(1)}^c) (\sigma_{\text{int}}) \gamma_{d\dot{b}}^i (\vartheta_{(2)}^d - \vartheta_{(1)}^d) (\sigma_{\text{int}}) |R\rangle |R\rangle$$

$$\longleftrightarrow \Sigma^{\dot{a}} \tilde{\Sigma}^i(z, \bar{z}) \Sigma^j \tilde{\Sigma}^{\dot{b}}(0) \sim \frac{1}{2|z|} \gamma_{c\dot{a}}^j \theta^c \gamma_{d\dot{b}}^i \tilde{\theta}^d(0)$$

⋮

These are consistent with the expected **LCSFT/MST** correspondence!

Conclusion and future directions

- We have confirmed the correspondence of interaction terms between LCSFT and MST by computing the contractions in LCSFT explicitly.
- The singular behaviors are the same.
- We found a simple expression of the prefactors.
- More detailed correspondence? $(\alpha_r, \mathcal{P}_r) \leftrightarrow (m, n, \int d\sigma, N), \dots$
(α -dependence, level matching projection, ...)
- Relation to Green-Schwarz's LCSFT ($SU(4)$ formalism)?
- Higher order terms of both LCSFT and MST?
- pp-wave background? (prefactor, contact terms, ...)
- Covariantized superstring field theory ? (using "pure spinor"?)
- ...

The remaining contractions (1-loop)

$$\begin{aligned} \text{"}H_1 Q_1^{\dot{a}}\text{"}: & \langle R | \langle R | e^{-\frac{T}{\alpha_1}(L_0^{(1)} + \tilde{L}_0^{(1)}) - \frac{T}{\alpha_2}(L_0^{(2)} + \tilde{L}_0^{(2)})} [\cosh \mathcal{Y}]_{ij} | V \rangle [\sinh \mathcal{Y}]_{k\dot{a}} | V \rangle \\ & \sim \delta^{ik} T^{-\frac{3}{2}} \gamma_{c\dot{a}}^j (\lambda_{(3)}^c + \lambda_{(6)}^c) (\sigma_{\text{int}}) | R \rangle \end{aligned}$$

$$\longleftrightarrow \quad \Sigma^j \tilde{\Sigma}^i(z, \bar{z}) \Sigma^{\dot{a}} \tilde{\Sigma}^k(0) \sim \frac{1}{z^{\frac{1}{2}} \bar{z}} \frac{\delta^{ik}}{\sqrt{2i}} \gamma_{c\dot{a}}^j \theta^c(0)$$

$$\begin{aligned} \text{"}Q_1^{\dot{a}} \tilde{Q}_1^{\dot{b}}\text{"}: & \langle R | \langle R | e^{-\frac{T}{\alpha_1}(L_0^{(1)} + \tilde{L}_0^{(1)}) - \frac{T}{\alpha_2}(L_0^{(2)} + \tilde{L}_0^{(2)})} [\sinh \mathcal{Y}]_{i\dot{a}} | V \rangle [\sinh \mathcal{Y}]_{b\dot{j}} | V \rangle \\ & \sim T^{-1} \gamma_{c\dot{a}}^j (\lambda_{(3)}^c + \lambda_{(6)}^c) (\sigma_{\text{int}}) \gamma_{d\dot{b}}^i (\lambda_{(3)}^d + \lambda_{(6)}^d) (\sigma_{\text{int}}) | R \rangle \end{aligned}$$

$$\longleftrightarrow \quad \Sigma^{\dot{a}} \tilde{\Sigma}^i(z, \bar{z}) \Sigma^j \tilde{\Sigma}^{\dot{b}}(0) \sim \frac{1}{2|z|} \gamma_{c\dot{a}}^j \theta^c \gamma_{d\dot{b}}^i \tilde{\theta}^d(0)$$

Precise relation between space-time fermions?